



2017-2018

Boys and Girls
Track and Field
Preview

Again this year, special emphasis is to be placed upon our Code of Ethics. It is requested that school administration, coaches and athletes make a special effort to review our Code this year in an effort to re-dedicate ourselves to our founding principles.

* * * * *

CODE OF ETHICS

IT IS THE DUTY OF ALL CONCERNED WITH
HIGH SCHOOL ATHLETICS:

1. To emphasize the proper ideals of sportsmanship, ethical conduct and fair play.
2. To eliminate all possibilities which tend to destroy the best values of the game.
3. To stress the values derived from playing the game fairly.
4. To show cordial courtesy to visiting teams and officials.
5. To establish a happy relationship between visitors and hosts.
6. To respect the integrity and judgment of sports officials.
7. To achieve a thorough understanding and acceptance of the rules of the game and the standards of eligibility.
8. To encourage leadership, use of initiative and good judgment by the players on a team.
9. To recognize that the purpose of athletics is to promote the physical, mental, moral, social and emotional well-being of the individual players.
10. To remember that an athletic contest is only a game - not a matter of life and death for player, coach, school, officials, fan, community, state or nation.

GOOD SPORTSMANSHIP, ETHICS AND INTEGRITY!!!
"YOU MAKE THE DIFFERENCE !!!"



10932 Pine Street
Los Alamitos, CA 90720
(562) 493-9500 * Fax (562) 493-6266

DATE: JANUARY 2018
TO: CIF-SS BOYS AND GIRLS TRACK AND FIELD COACHES
FROM: RAINER WULF, ASSISTANT COMMISSIONER
SUBJECT: 2018 TRACK AND FIELD SEASON

*** WELCOME TO THE 2018 TRACK AND FIELD SEASON ***

The Track and Field Preview Packet has been prepared to assist you in the organization of your school program. The information is important in preparation for the upcoming season. Please share this information with your assistant coaches.

The following items are included in the packet:

1. Calendar Dates
2. Championship dates for 2018 Season
3. Playoff Groupings
4. Blue Book Rules --
 - A. Accountability Rule
 - B. Player Conduct Rule
 - C. Other Points of Interest
5. Supervision of Athletes
6. Discus Cage Specifications
7. CIF Rules for Pole Vault
8. Pole Vault Weight Verification Form
9. Rule Revisions for 2018
10. Sanctioned Event List

2017 TRACK AND FIELD ADVISORY & MANAGEMENT COMMITTEES

Veronica Amarasekara, Claremont HS
Rich Benoy (Mgt.)
Al Britt
John Corona, M.L. King HS
Rob Dearborn, Moorpark HS
Rich Ede (Mgt.)
Mark Gardner, Corona HS
Hal Harkness (Mgt.)
Steve Hill (Mgt.)
Dennis Kelly, Trabuco Hills HS
Jonas Koolsbergen, Harvard-Westlake HS
Nicki Kosick, San Dimas HS
Van Latham, Carpinteria HS
Bryan Leighliter, Gahr HS

Kory Anderson, Ventura HS
Bob McGuire (Mgt.)
Joe McNab, Notre Dame/SO HS
Mary Perez, Camarillo, HS
Ken Quinn, Serrano HS
Jack Recla (Mgt.)
Mark Rose, Paso Robles HS
Rob Shock, Poly/Long Beach HS (Mgt.)
Keith Thompson, Walnut HS
Brenton Youngren, Irvine HS

CIF SOUTHERN SECTION TRACK AND FIELD CALENDAR DATES

The following is a capsule of the CIF Southern Section calendar for the upcoming season:

STARTING DATE FOR INTERSCHOLASTIC CONTEST

No interscholastic meets (practice, invitational or league) may be scheduled prior to SATURDAY, February 24, 2018.

LAST LEAGUE AND/OR NON-LEAGUE CONTEST

All league competition for both boys and girls teams must end on or before Friday, May 4, 2018. Schools may compete until May 5, 2018, for non-league contests.

IMPORTANT! IMPORTANT! IMPORTANT!

*****PLEASE NOTE: ENTRIES INTO THE CIF-SS PRELIMS FROM LEAGUE MEET MANAGERS WILL BE DUE IN THE CIF SOUTHERN SECTION OFFICE BY 11:59 P.M. ON FRIDAY, MAY 4, 2018. LEAGUES MUST SCHEDULE THEIR LEAGUE FINALS PRIOR TO FRIDAY!!! *****

CIF-SS TRACK AND FIELD CHAMPIONSHIP DATES FOR 2018

This may be used for preliminary planning, as more comprehensive information will follow in a later bulletin.

BOYS AND GIRLS VARSITY

All Prelims are on Saturday, May 12, 2018 - Field Events: 11:00 a.m.; Running Events 12 Noon

DIVISION 1 PRELIMS

Trabuco Hills HS Jack Recla, Meet Mgr. (949) 285-4893
jackrecla@cox.net

DIVISION 2 PRELIMS

Moorpark HS -- Rob Dearborn, Meet Mgr. (805) 378-6305, Ext. 2363
rdearborn@mrpk.org

DIVISION 3 PRELIMS

Estancia HS -- Steve Moreno, Meet Mgr. (714) 349-2743
cmhs.xc.tf@gmail.com
Matthew Redding, Meet Mgr. (714) 609-7322
Reddingm88@gmail.com

DIVISION 4 PRELIMS

Carpinteria HS -- Van Latham, Meet Mgr. 805) 684-4107
vlatham@cusd.net
Div 4 Prelim information : <http://www.warriorcountry.com/track/CIF.htm>

DIVISIONAL FINALS

El Camino College -- **Saturday, May 19, 2018**
Meet Managers: Jack Recla, Steve Hill, Rich Ede
Stadium Opens for Athletes - 8:30 am
Stadium Opens for Spectators - 9:30 am
Field Event Warm-Up Only - 10:00 am
Start Pole Vault Competition - 10:30 am
Start All Field Event Competition - 11:00 am
Start Running Events - 1:00 pm

MASTERS MEET - STATE QUALIFYING

El Camino College -- **Saturday, May 26, 2018**
Meet Managers: Jack Recla, Steve Hill, Rich Ede
Stadium Opens - 8:30 am
Start Field Event Competition - 11:00 am
Start Running Events - 1:00 pm

STATE TRACK MEET

Buchanan H.S. -- Friday and Saturday, June 1 and 2, 2018
Clovis

CIF SOUTHERN SECTION 2018 TRACK AND FIELD PLAYOFF DIVISIONS

As a result of the CIF Southern Section Council decision (*March 23, 2000), for the 2017-2018 Track and Field season, league qualifiers for the CIF Southern Section Prelims will advance to their division based on the 2016-2017 CBED enrollment figures for their individual schools.

Track and Field Division Placements for 2017-2018 can be found at:

[2018 CIFSS Track and Field Divisions](#)

Division placements are also posted on the CIF-SS website @ www.cifss.org > Track and Field > Playoff Divisions

In order to address some concerns expressed by the Track and Field Advisory Committee and in an effort to avoid introducing, at this time, more drastic changes (i.e., additional minimum standards, capping entries, etc.) you will note that there have been some slight adjustments in the divisional makeup.

Leagues using Hy-Tek for their prelim/final meets must only use the school abbreviations listed on the divisional breakdown sheets. No other abbreviations can be used.



JL CUSTOM JACKETS

OFFICIAL LICENSED PATCH AND JACKET MANUFACTURER



VARSITY JACKET SPECIAL

\$245.00

WOOL BODY WITH LEATHER
SLEEVES AND POCKETS

VARSITY LETTER SEWN
ON FRONT

MAKE AND SEW ON UP TO
3 SPORT EMBLEMS

EMBROIDER FIRST NAME,
SCHOOL NAME, MASCOT
NAME AND 1 SPORT
ONTO THE FRONT

CREATE AND SEW ON A
CUSTOM GRADUATING YEAR



You can design and purchase
your own custom patches
on our website.

STANDARD GIRLS PACKAGE:

\$ 230.00

ALL WOOL BODY AND SLEEVES
WITH A WOOL HOOD

To Order Call:

(951) 867-3200

or visit us on the web:

www.jlcustomjackets.com

7161 Old 215 Frontage Road, Moreno Valley, CA

Fax (951) 867-3277



• PRICES ARE SUBJECT TO CHANGE WITHOUT NOTICE •

**CIF Southern Section
2018 Boys and Girls Track and Field
Hy-Tek Abbreviations**

<u>School</u>	<u>(Hy-Tek Abbreviations)</u>	<u>School</u>	<u>(Hy-Tek Abbreviations)</u>
Academy of Academic Ex.	(AFAE)	California	(CALF)
Adolfo Camarillo	(CAMA)	California City	
Agoura	(AGOU)	California Military Academy	(CAMY)
Alemanya	(ALEM)	Calvary Chapel/Downey	(CALC)
Alhambra	(ALHA)	Calvary Chapel/Santa Ana	(CCSS)
Aliso Niguel	(ALNI)	Calvary Chapel/Murrieta	(CCMU)
Alverno	(ALVE)	Campbell Hall	(CAHA)
Alta Loma	(ALLO)	Cantwell-Sacred Heart	(CANT)
Anaheim	(ANAH)	Canyon/Anaheim	(CAAN)
Animo Leadership	(ANLE)	Canyon/Canyon Country	(CANY)
Antelope Valley	(ANVA)	Canyon Springs	(CASP)
Antelope Valley Christian	(ANCH)	Capistrano Valley	(CAPO)
Apple Valley	(APVA)	Carpinteria	(CARP)
Aquinas	(AQUI)	Carter	(CART)
Arcadia	(ARCA)	Cate	(CATE)
Archer School for Girls (G)	(ARSG)	Cathedral (B)	(CATH)
Arlington	(ARLI)	Cathedral City	(CACI)
Arrowhead Christian	(ARCH)	Centennial/Compton	(CENC)
Arroyo	(AROY)	Centennial/Corona	(CENN)
Arroyo Grande	(ARGR)	Century	(CENT)
Arroyo Valley	(ARVA)	Cerritos	(CERR)
Artesia	(ARTE)	Chadwick	(CHAD)
Atascadero	(ATAS)	Chaffey	(CHAF)
Ayala	(AYAL)	Chaminade	(CHAM)
Azusa	(AXUS)	Channel Islands	(CHIS)
Baldwin Park	(BAPA)	Chaparral	(CHAP)
Banning	(BANG)	Charter Oak	(CHOA)
Barstow	(BARS)	Chino	(CHIN)
Bassett	(BASS)	Chino Hills	(CHHI)
Beaumont	(BEAU)	Citrus Hill	(CIHI)
Beckman	(BEMA)	Claremont	(CLAR)
Bell Gardens	(BEGA)	Coachella Valley	(COVA)
Bell-Jeff	(BELJ)	Colony	(COLO)
Bellflower	(BELF)	Colton	(COLT)
Bethel Christian/Riverside	(BTCR)	Compton	(COMP)
Beverly Hills	(BEHI)	Cornerstone Chr/Camarillo	(CRNS)
Big Bear	(BIBE)	Corona	(CORO)
Bishop Amat	(BIAM)	Corona del Mar	(CODM)
Bishop Diego	(BIDI)	Costa Mesa	(COME)
Bishop Montgomery	(BIMO)	Covina	(COVI)
Bishop Union	(BISH)	Crean Lutheran	(CLSO)
Blair	(BLAI)	Crescenta Valley	(CRVA)
Bloomington	(BLOM)	Crespi (B)	(CRES)
Bolsa Grande	(BOGR)	Crossroads	(CROS)
Bonita	(BONI)	CSDR	(CSDR)
Boron	(BORO)	Culver City	(CUCI)
Brea Olinda	(BROL)	Cypress	(CYPR)
Brentwood	(BREN)	Damien (B)	(DAMI)
Brethren Christian	(BRET)	Dana Hills	(DAHI)
Buena	(BUEN)	Death Valley Academy	(DEAT)
Buena Park	(BUPA)	Desert	(DESE)
Burbank	(BURB)	Desert Christian/Lancaster	(DESL)
Burroughs/Burbank	(BURO)	Desert Christian/BD	(DEBD)
Burroughs/Ridgecrest	(BURO)	Desert Hot Springs	(DEHO)
Cabrillo/Lompoc	(CABR)	Desert Mirage	(DEMI)
Cabrillo/Long Beach	(CABL)	Diamond Bar	(DIBA)
Cajon	(CAJO)	Diamond Ranch	(DIRA)
Calabasas	(CALB)	Dominguez	(DOMI)

<u>School</u>	<u>(Hy-Tek Abbreviations)</u>
Don Bosco (B)	(DOBO)
Don Lugo	(DOLU)
Dos Pueblos	(DPHS)
Downey	(DOWN)
Duarte	(DUAR)
Dunn	(DUNN)
Eastside	(EASI)
Edison	(EDIN)
Eisenhower	(EISE)
El Dorado	(ELDR)
El Modena	(ELMO)
El Monte	(ELMT)
El Rancho	(ELRA)
El Segundo	(ELSE)
El Toro	(ELTO)
Elsinore	(ELSI)
Esperanza	(ESPE)
Estancia	(ESTA)
Etiwanda	(ETIW)
Excelsior Education Center	(EXED)
Fillmore	(FILL)
Flintridge Prep	(FLPR)
Flintridge Sacred Heart (G)	(FLSH)
Fontana	(FONT)
Foothill	(FHIL)
Foothill Technology	(FHTC)
Fountain Valley	(FOVA)
Fullerton	(FULL)
Gabrielino	(GABR)
Gahr	(GAHR)
Ganesh	(GANE)
Garden Grove	(GAGR)
Garey	(GARE)
Gladstone	(GLAD)
Glendale	(GLND)
Glendora	(GLEN)
Glenn	(GLNN)
Godinez	(GODI)
Golden Valley	(GOVA)
Granite Hills	(GHLS)
Great Oak	(GROA)
Hamilton	(HAML)
Hart	(HART)
Harvard-Westlake	(HAWE)
Hawthorne	(HAWT)
Hemet	(HEME)
Heritage	(HERI)
Hesperia	(HESP)
Hesperia Christian	(HECR)
Highland	(HIGL)
Holy Family (G)	(HOFA)
Holy Martyr=s	(HOMA)
Hoover	(HOOV)
Hueneme	(HUEN)
Huntington Beach	(HUBE)
Immaculate Heart (G)	(IMMU)
Immanuel Christian	(IMMN)
Indio	(INDI)
Inglewood	(INGL)
Irvine	(IRVI)
Jordan	(JORD)
JSerra	(JSER)
Jurupa Valley	(JURU)

<u>School</u>	<u>(Hy-Tek Abbreviations)</u>
Kaiser	(KAIS)
Katella	(KATE)
Kennedy	(KNSS)
Kern Valley	(KEVA)
Kilpatrick (B)	(KILP)
King, M.L.	(KGML)
Knight	(KNIG)
La Canada	(LACA)
La Habra	(LAHA)
La Mirada	(LAMI)
La Puente	(LAPU)
La Quinta/La Quinta	(LAQU)
La Quinta/Westminster	(LAQN)
La Reina (G)	(LARE)
La Salle	(LASA)
La Serna	(LASE)
La Sierra	(LASI)
La Sierra Academy	(LSAC)
Laguna Beach	(LABE)
Laguna Hills	(LAHI)
Lakeside	(LAKS)
Lakewood	(LAKE)
Lancaster	(LANC)
Leuzinger	(LEUZ)
Lighthouse Christian	(LGXH)
Linfield Christian	(LINF)
Littlerock	(LITT)
Loara	(LOAR)
Lompoc	(LOMP)
Lone Pine	(LOPI)
Los Alamitos	(LOSA)
Los Altos	(LOST)
Los Amigos	(LOAM)
Los Angeles Adventist	(LNAT)
Los Angeles Baptist	(LABA)
Los Osos	(LOOS)
Louisville (G)	(LOUI)
Loyola (B)	(LOYO)
Lutheran/La Verne	(LULV)
Lutheran/Orange	(LUOR)
Lynwood	(LYNW)
Magnolia	(MAGN)
Malibu	(MALI)
Maranatha	(MARA)
Marina	(MARI)
Mark Keppel	(MAKE)
Marlborough (G)	(MARL)
Marshall	(MARH)
Mary Star of the Sea	(MSEA)
Marymount (G)	(MARY)
Mater Dei	(MADE)
Mayfair	(MAYF)
Mayfield (G)	(MYFL)
Milken Community	(MKLN)
Miller, A.B.	(ABMI)
Millikan	(MILK)
Mira Costa	(MICO)
Mission Viejo	(MIVI)
Mojave	(MOJA)
Monrovia	(MORO)
Montclair	(MOCL)
Montclair Prep	(MOPR)

<u>School</u>	<u>(Hy-Tek Abbreviations)</u>	<u>School</u>	<u>(Hy-Tek Abbreviations)</u>
Montebello	(MOBE)	Quartz Hill	(QUHI)
Moorpark	(MOOR)	Ramona	(RAMO)
Moreno Valley	(MOVA)	Ramona Convent (G)	(RACV)
Morningside	(MORN)	Rancho Alamitos	(RAAL)
Morro Bay	(MOBA)	Rancho Cucamonga	(RACU)
Mountain View	(MOVV)	Rancho Verde	(RAVE)
Muir	(MUIR)	Redlands	(REDL)
Murrieta Valley	(MUVA)	Redlands East Valley	(REEA)
New Roads	(NERO)	Redondo Union	(REDO)
Newbury Park	(NEPA)	Rialto	(RIAL)
Newport Harbor	(NEHA)	Ribet Academy	(RIAC)
Nia Educational Charter	(NEDC)	Righetti	(RIGH)
Nipomo	(NIPO)	Rim of the World	(RIWO)
Nogales	(NGLE)	Rio Mesa	(RIME)
Norco	(NORC)	Riverside Christian	(RVCH)
Nordhoff	(NORD)	Riverside Prep	(RIVP)
Norte Vista	(NOVE)	Roosevelt, Eleanor	(ROEL)
North, J.W.	(NRTH)	Rosamond	(ROSA)
North Torrance	(NOTO)	Rosary (G)	(RORY)
Northview	(NRVW)	Rosemead	(ROSE)
Northwood	(NRWO)	Rowland	(ROWL)
Norwalk	(NORW)	Royal	(ROYL)
Notre Dame/Riverside	(NDAM)	Rubidoux	(RUBI)
Notre Dame/Sherman Oaks	(NODA)	Sacred Heart of Jesus (G)	(SHJE)
Notre Dame Academy (G)	(NDAD)	Saddleback	(SADD)
Nuvview Bridge	(NUBR)	Saddleback Valley Christian	(SVCH)
Oak Park	(OAPA)	Sage Hill	(SGHI)
Oaks Christian	(OACH)	Salesian (B)	(SLES)
Oakwood	(OAWO)	San Bernardino	(SABR)
Ocean View	(OCVI)	San Clemente	(SCLE)
Ojai Valley	(OJVA)	San Dimas	(SADI)
Ontario	(ONTA)	San Gabriel Mission (G)	(SGME)
Ontario Christian	(ONCH)	San Gabriel	(SAGA)
Orange	(ORAN)	San Geronio	(SAGO)
Orcutt Academy	(ORAC)	San Jacinto	(SAJA)
Oxford Academy	(OXAC)	San Jacinto Valley Academy	(SIAA)
Oxnard	(OXNA)	San Juan Hill	(SJUH)
Pacific	(PACI)	San Luis Obispo	(SALU)
Pacific Hills	(PAHI)	San Marcos	(SAMA)
Pacifica/Garden Grove	(PAFE)	San Marino	(SNMR)
Pacifica/Oxnard	(PAOX)	Santa Ana	(SAAN)
Pacifica Christian	(PACR)	Santa Ana Valley	(SAVA)
Palm Desert	(PADE)	Santa Barbara	(SABA)
Palm Springs	(PASP)	Santa Clara	(SACL)
Palmdale	(PADA)	Santa Fe	(SAFE)
Paloma Valley	(PLMV)	Santa Margarita	(STMA)
Palos Verdes	(PSVE)	Santa Maria	(STMR)
Paraclete	(PARC)	Santa Monica	(SAMO)
Paramount	(PARA)	Santa Paula	(SNPL)
Pasadena	(PASA)	Santa Ynez	(SAYN)
Paso Robles	(PARO)	Santiago/Corona	(SNTO)
Patriot	(PATR)	Santiago/Garden Grove	(SNTO)
Peninsula	(PENI)	Saugus	(SAGU)
Perris	(PERR)	Savanna	(SAVN)
Pioneer	(PNER)	Schurr	(SCHU)
Pioneer Valley	(PIOV)	Seegerstrom	(SEGR)
Poly/Long Beach	(POLB)	Serra	(SRSS)
Poly/Pasadena	(POPA)	Serrano	(SERN)
Poly/Riverside	(PORI)	Servite (B)	(SERV)
Pomona	(POMO)	Shadow Hills	(SHHI)
Price	(PRIC)	Shandon	(SHAN)
Providence	(PROV)	Sherman Indian	(SHIN)

School	(Hy-Tek Abbreviations)
Sierra Canyon	(SICA)
Sierra Vista	(SIVI)
Silver Valley	(SIVL)
Silverado	(SILV)
Simi Valley	(SIVA)
Sonora	(SONR)
South Bay Lutheran	(SBLU)
South El Monte	(SOEM)
South Hills	(SOHI)
South Pasadena	(SOPA)
South Torrance	(SOTO)
St. Anthony	(STAN)
St. Bernard	(STBE)
St. Bonaventure	(STBO)
St. Francis (B)	(STFC)
St. Genevieve	(STGE)
St. John Bosco (B)	(STJB)
St. Joseph/Santa Maria	(STJO)
St. Joseph/Lakewood (G)	(STJP)
St. Lucy=s (G)	(STLU)
St. Margaret=s	(STMG)
St. Mary=s Academy (G)	(STMC)
St. Matthias (G)	(SMTT)
St. Monica	(SMON)
St. Monica Catholic	(SMON)
St. Paul	(STPA)
Sultana	(SULT)
Summit	(SUMT)
Sunny Hills	(SUHI)
Tahquitz	(TAHQ)
Temecula Prep	
Temecula Valley	(TEVA)
Templeton	(TEMP)
Temescal Canyon	(TECA)
Temple City	(TECI)
Tesoro	(TESO)
Thacher	(THAC)
Thousand Oaks	(THOA)
Torrance	(TORR)
Trabuco Hills	(TRHI)
Trinity Lutheran	(TRLU)
Trona	(TRON)
Troy	(TROY)
Tustin	(TUST)
Twentynine Palms	(TWEN)
University	(UNIV)
Upland	(UPLN)
Upland Christian	(ULCN)
Valencia/Placentia	(VAPL)
Valencia/Valencia	(VALE)
Valley Christian/Cerritos	(VCHR)
Valley View	(VAVI)
Vasquez	(VASQ)
Ventura	(VENT)
Verbum Dei (B)	(VEDE)
Victor Valley	(VIVA)
Victor Valley Christian	(VVCH)
Villa Park	(VIPA)
Village Christian	(VLCH)
Village Glen	(VIGL)
Villanova Prep	(VIPR)

School	(Hy-Tek Abbreviations)
Vista del Lago	(VIDL)
Vista Murrieta	(VIMU)
Vistamar	(VIMA)
Walnut	(WALN)
Warren	(WARR)
Webb	(WEBB)
West Covina	(WECO)
West Ranch	(WERN)
West Torrance	(WETO)
West Valley	(WEVL)
West Valley Christian	(WVCH)
Western	(WSTN)
Western Christian	(WCHR)
Westlake	(WELA)
Westminster	(WEMI)
Westridge (G)	(WESR)
Whitney	(WHIT)
Whittier	(WHTT)
Whittier Christian	(WHCH)
Wilson/Hacienda Heights	(WLHH)
Wilson/Long Beach	(WILB)
Windward	(WINW)
Woodbridge	(WOBR)
Woodcrest Christian	(WDCH)
Xavier Prep	(XAVI)
Yucaipa	(YUCI)
Yucca Valley	(YUCA)

2018 QUALIFYING STANDARDS

1. League champions in the varsity league finals meet in each event will automatically qualify.
2. Second and third place finishers in the varsity league finals meet will qualify **IF** they meet the minimum standard for their event.
3. At-large entrant standards will be different from the minimum standards. (****At-large standards can only be achieved in varsity league finals competition.****)

2018 QUALIFYING STANDARDS FOR 2nd & 3rd PLACE IN LEAGUE FINALS and 2018 QUALIFYING STANDARDS FOR FREE LANCE & AT-LARGE ENTRIES

will be posted in the Track and Field Bulletin

LEAGUE MEET MANAGERS, LEAGUE COORDINATORS

All leagues should have, in their constitution, language dealing with the submission of league entries to the CIF Prelims. The process utilized for entry submission **must** be consistent with that approved language.

“WILD CARD” INCLUSION INTO CIF-SS PRELIMS

Any athlete or relay competing at their league finals meet who fails to achieve a top three result or a mark that meets the “at-large” standard for their CIF-SS division, but whose mark at their league finals meet is in the top ten (including ties) for their Division as published on the CIF-SS Prelims performance list will advance into the meet.

Coaches with individual athletes or relay teams whose performance at the league finals meet puts them into this situation should confirm their top ten status on the final CIF-SS Prelim performance list on EPI and contact the Prelim Meet Manager **via email** for their division with official results from their league finals meet so that their athlete can be included in the CIF-SS Prelim field as a “Wild Card” entry.

The **email** deadline for “Wild Card” entry submission to the Prelim Meet Manager is **10:00am** on the **Monday morning** following the submission of entries by league meet managers. League meet managers must submit “Wild Card” entry via email to the Divisional Prelim Meet Manager. Email information is listed below. **Anyone who misses the deadline will not be entered after that point.**

DIVISION 1 PRELIMS

Trabuco Hills HS -- Jack Recla, Meet Mgr. - jackrecla@sbcglobal.net

DIVISION 2 PRELIMS

Moorpark HS -- Rob Dearborn, Meet Mgr. - rdearborn@mrpk.org

DIVISION 3 PRELIMS

Estancia HS -- Steve Moreno, Meet Mgr. – cms.xc.tf@gmail.com
Matthew Redding, Meet Mgr. – reddingm88@gmail.com

DIVISION 4 PRELIMS

Carpinteria HS -- Van Latham, Meet Mgr. - vlatham@cusd.net

BLUE BOOK RULES - SPECIAL POINTS OF INTEREST

A) ACCOUNTABILITY RULE --

125.1 -- COACH EJECTION -- Upon the ejection of a coach from any CIF-SS contest, it is the responsibility of the principal of said school to file a letter of explanation with the CIF Southern Section Office which includes the circumstances surrounding the matter and what action the principal has taken to prevent a recurrence. Said correspondence is to be filed within THREE school days of notification of the ejection. Additionally, upon ejection, the head or assistant coach shall be disqualified from participating in the remainder of the game and will be ineligible for the team's next contest. A second ejection will constitute a two contest suspension and a third ejection will cause suspension for the remainder of the season.

125.2 -- FAILURE TO COMPLETE A CONTEST -- When a school fails to complete a contest, due to a coach pulling his/her team from the floor, court or field, it is MANDATORY that the CIF-SS Office be notified by the Principal within 24 hours (excluding holidays and weekends). The competing schools and officials will be required to file written reports, and after review of the aforementioned material, the principal of the school involved will be required to respond to the CIF Southern Section Office concerning his/her investigation of the incident.

QUESTION: *How serious is such action?*

ANSWER: *It has been the position of the CIF-SS Executive Committee to expect the building principal of the school concerned to relieve the coach from his/her assignment for the balance of that season or the Executive Committee is empowered to consider recommendations for additional penalties.*

B) 2919. PLAYER CONDUCT -- Any player ejected for any reason or any player who leaves the confines of the bench or team area during a fight that may break out or has broken out shall be disqualified from participating in the remainder of the game and will be ineligible for the team's next contest. A second ejection will constitute a two contest suspension and a third ejection will cause suspension for the remainder of the season. A player who was ejected from the previous contest who, knowingly or unknowingly, participates in or is in attendance at the next contest, will result in the forfeiture of that contest.

QUESTION: *What is meant by attendance at a contest?*

ANSWER: *Attendance is defined as being present at the team bench/area, inside a gymnasium, stadium or playing area. Students ejected from a game in progress should remain under supervision of school staff. The intent of this rule is that the ejected person is not in attendance at the contest.*

C) OTHER POINTS OF INTEREST -

1. MAXIMUM CONTESTS -- An individual of a track and field team will be permitted to enter and participate in no more than a total of 13 dual, triangular or invitational (sanctioned) meets during the season, not including all league or CIF-SS Championships.
2. MAXIMUM NUMBER OF MEETS/DAY -- No student will be permitted to enter two different meets on the same day. A student may compete in different classifications during a calendar week but not in the same meet. League prelims and finals are considered to be one meet, as are the CIF Southern Section Prelims and Finals.

MAXIMUM NUMBER OF EVENTS: A STUDENT MAY ENTER A TOTAL OF NOT MORE THAN FOUR EVENTS IN ANY ONE MEET. These may be four running events or four field events or any combination of track and field events totaling not more than four.

3. OUTSIDE COMPETITION -- "Unattached competition is permissible for a student in other than school contests during the season of sport."
4. LEVEL OF COMPETITION -- No student shall participate in more than one level of competition in the same sport in the same day.
5. DISCUS CAGE -- Mandatory (See diagram)

The use of a protective cage is required for the discus event. There will be a rear to the cage as well as sides that extend forward at least up to the front of the ring and preferably several feet beyond the front of the ring.

RULE 2901 - LANDING SECTOR FOR DISCUS AND SHOT PUT

For safety reasons, the landing sector for both the discus and shot put will be 34.92 degrees. The present width of area for restraining spectators and other athletes, not throwing the shot or discus, will remain the same as per National Federation rules (February 1998, Federated Council)

SANCTIONS

Visit our website for the latest approved sanctioned events at www.cifss.org.

SUPERVISION OF ATHLETES

The Southern Section Office has experienced a problem which has perpetuated itself over the past few years as it pertains to proper supervision and entry of student-athletes in the post-season playoffs.

The situation relates only to individual sports, i.e. CROSS COUNTRY, INDIVIDUAL TENNIS, TRACK, SWIMMING, etc. and the official recognition and registration of entrants at the respective playoff sites.

State and Southern Section Rule 503 states:

No CIF team (i.e., individual) shall participate in inter-scholastic or approved competition with any other team unless the CIF team is under supervision as required by the California Administrative Code 49032 and CIF By-Law #503 (F). (Additionally, refer to Rule 123.) The supervisor must remain in attendance at all times.

Those persons APPROVED FOR SUPERVISION PURPOSES are limited to:

- A. Certificated personnel
- B. Certified Coaches (certified credentialed coaches)
- C. Non-certificated temporary coaches (certified walk-on coaches.)

(It should be noted that schools representing the same DISTRICT may send one credentialed or certified supervisor for three or four athletes. These individuals have been recognized and are to continue to be recognized for registration and participation purposes in that the district has assigned the supervisory role for all students from its= member schools to this one individual.)

However, the concern is for those students who ARE NOT accompanied by a faculty representative and report to the playoff site by themselves or with a parent. ***GIVING PARENTS THE SUPERVISION AUTHORITY, WHETHER IN WRITING OR NOT, DOES NOT MEET THE STANDARDS SET FORTH IN THE ABOVE REGULATIONS. This also applies to parents who are the student=s private coach but are not under contract to the member school.***

PLEASE NOTE, THIS RULE WAS REVIEWED BY BOTH THE STATE CIF OFFICE, IT=S GENERAL COUNSEL AND THE SOUTHERN SECTION EXECUTIVE COMMITTEE. IT HAS BEEN REAFFIRMED THAT THE INTERPRETATION STAND AS ABOVE AND THAT ANY STUDENT REPORTING FOR COMPETITION WHO IS NOT UNDER DIRECT SUPERVISION IN ACCORDANCE WITH STATE AND SOUTHERN SECTION RULE 503, IS TO BE DENIED ENTRY FOR PARTICIPATION IN THE COMPETITION.

As pointed out by the Southern Section and State CIF attorney, there are inherent liability problems when an individual competes in violation of said rule. Please review this rule with your staff in that it will be strictly enforced as per the above application.



FUEL YOUR GAME FROM BEGINNING TO END. WIN FROM WITHIN.

©2016 S-VC, Inc. GATORADE and the G BOLT design are registered trademarks of S-VC, Inc.

CIF SOUTHERN SECTION PARTNERS

Proudly Supporting Southern California Student-Athletes



SOUTHERN CALIFORNIA FORD DEALERS

Title Sponsor and Official Automobile of the CIF Southern Section – FORD Championships



Official Ball of the CIF-SS



Official Home of the
CIF-SS FORD Championships



Official Event
Merchandise
www.ciftshirts.com



Official Baseball
of the CIF-SS



Official Water Polo Ball
of the CIF-SS



Official Apparel
of the CIF-SS



Official Partner
of the CIF-SS



Official Partner
of the CIF-SS



Official Sports
Fuel Provider
of the CIF-SS



Official Source for
CIF-SS Scores & Stats



Supporting Partner
of the CIF-SS



Supporting Partner
of the CIF-SS



Official Partner
of the CIF



Supporting Partner
of the CIF-SS



Supporting Partner
of the CIF



Southern California Section
Supporting Partner
of the CIF-SS



Official Tennis Ball
of the CIF-SS



Official Tennis Supplier
of the CIF-SS



Official Badminton
Supplier
of the CIF-SS



Official Patch
Provider
of the CIF-SS

CIF RULES FOR THE POLE VAULT

The State CIF issues the following rules directive for immediate implementation in the pole vault event. National Federation Track & Field Rules 7-5-3 and 7-5-4 in the pole vault require important and necessary modifications in the conduct of the event. State High School Associations may exercise their authority to require a stricter enforcement of these rule changes. CIF coaches and officials must comply with and enforce all National Federation and State CIF rules. Failure to do so may jeopardize the safety of the event.

1. Verification of Weight

All coaches of high school track and field teams are required to present written verification to the starter-referee listing the current weight of each student pole vaulter prior to each high school meet. Such verification is to be recorded on an official **pole vault event card** appropriately designed with a space for the listing of the vaulter's weight plus the signature/initials of the coach. The pole vault event card is an official record.

a) **Dual Meets** - Each school shall enter competitors on their own event cards i.e. entrants from two or more schools should not be on the same entry card. Each school will be responsible for retaining a permanent file of the event cards in the office of its athletic director.

b) **Invitationals, League Championships, Section Championships, State Championships** - All entrants may be listed on a single event form and coaches are required, at check-in time, to enter the current weight for each vaulter, and place their initials on that official event form. The meet director is responsible for retaining the event form as an official record on permanent file.

2. Inspection of the Poles - Penalty for Violation

A. When the athlete checks in at the event, the pole vault event judge and/or the starter-referee will inspect the poles of each student vaulter to compare the signed, official pole vault event card (which lists each vaulter's current weight) against the numerical pole rating of all poles to be used by that student-vaulter. The above inspection shall be completed in order to approve each vaulter for subsequent practice vaults and official vaulting attempts. **Athletes who violate National Federation rule 7-5-3 which requires a vaulter to use a pole rated at the vaulters body weight, or above, will be disqualified from the pole vault event.**

NOTE: The CIF is not suggesting the event judge check the pole weight rating for every jump taken, but that the judge spot check the pole during warm-ups and competition for adequate compliance.

It is further clarified that should an athlete be disqualified, it would be a disqualification from the pole vault event only and not from the meet itself.

B. The pole vault event judge and/or starter referee may periodically check the poles of each student vaulter during practice or official vaulting attempts to insure: 1) the proper placement of a top hand-hold band 2) the numerical pole rating in one-inch numerals 3) proper pole bindings

REMARKING OF OLDER POLES

When the etching of printing listing the manufacturer's pole rating is no longer clearly visible, the pole may be remarked for possible use provided the pole has been reflexed according to the original manufacturer's specifications. The poles' numerical rating must be clearly marked according to National Federation rule specifications.

3. **Safe Hand-Hold Zone - CIF Penalty for Violation**

The top of the safe hand-hold zone shall be clearly marked with a one-inch circular band around the pole in contrasting color (National Federation Rule 7-5-3). **By State CIF rule, a violation of the safe hand-hold zone by a student-vaulter shall be deemed a failed try. A further violation shall be cause for disqualification.**

When checking for compliance, the one-inch circular band marking the top of the safe hand-hold zone must be "clearly visible" after the vaulter places his/her top hand next to that band.

4. **Variable Weight Poles i.e. Training or Technique Poles**

By State CIF rule, the variable weight pole shall not be used in any CIF high school competition. We note that expert vaulting coaches indicate there is some value in a variable weight pole, but its use must be restricted for short run, drill work and only during practice or training sessions and always under skilled supervision.

5. **Box Collar Padding Requirement**

7-5-24: Padding meeting the ASTM Specification Standards has been required since the start of the 2014-15 track season. Rationale: For the purpose of minimizing risk of injury to a pole vaulter, require that planting box padding shall meet the applicable ASTM Specification Standard.

ALL NATIONAL FEDERATION AND CIF RULES APPLY WHENEVER THE POLE VAULT EVENT IS CONTESTED REGARDLESS OF WHETHER THE EVENT IS SCORED OR NOT.



10932 Pine Street
Los Alamitos, CA 90720
(562) 493-9500 * (562) 493-6266

DATE: August 27, 2002
TO: Athletic Directors, Track and Field Coaches
FROM: Rainer Wulf, Assistant Commissioner
SUBJECT: Pole Vault Rules Changes

The California Interscholastic Federation (CIF), through its affiliation with the National Federation of State High School Associations (NFHS), has adopted rules which set the legal minimum size and standards of the pole vault pits **effective immediately for the 2003 track and field season**. The new rules are as follows:

Effective immediately, the landing surface measured beyond the back of the standard base protection pad, shall be a minimum of **19'8"** wide, and the dimension of the landing surface in back of the vaulting box to the back of the landing pad shall be **16'5"** deep. The material in the pad shall be high enough and of a composition that will **decelerate the landing**. When the landing pad is made up of two or more sections, the landing surface shall include a common cover or pad extending over all sections. (7-5-7) (7-5-8).

If the edges of the front, or landing pad, immediately adjacent to the planting box are not tapered, the back of the cutout may be placed no farther than **3 inches** from the top of the back of the planting box. (7-5-8)

The upright standards that support the crossbar shall be not less than **13'8" (4.16m) or more than 14'8" (4.48m)** apart, and the standards must include pins or holes for them to support the crossbar. (7-5-10)

The non-metal crossbar shall be 14'10" (4.52m) in length, of uniform thickness, and shall have a weight of not more than 5 pounds. (7-5-11)

A planting box shall be located midway between the standards. This box shall be constructed of concrete, fiberglass, metal, or other hard surface material into which the vaulting pole is placed. The box shall be of dimensions indicated in the accompanying Diagrams A and B, and it shall be placed so the top edges are at ground level. The box in Diagram B shall be constructed so that the sides slope outward at the end nearest the landing pit. The end of the planting box shall be placed at an angle of 105 degrees with the base of the box. **The front edge of the box shall not extend above the grade of the runway surface.** NOTE: It is recommended the planting box be of a color contrasting to the color of the runway. (7-5-12)

A minimum of 2" dense foam padding (box collar) shall be used to pad any hard and unyielding surface including **between the planting box and all pads.**

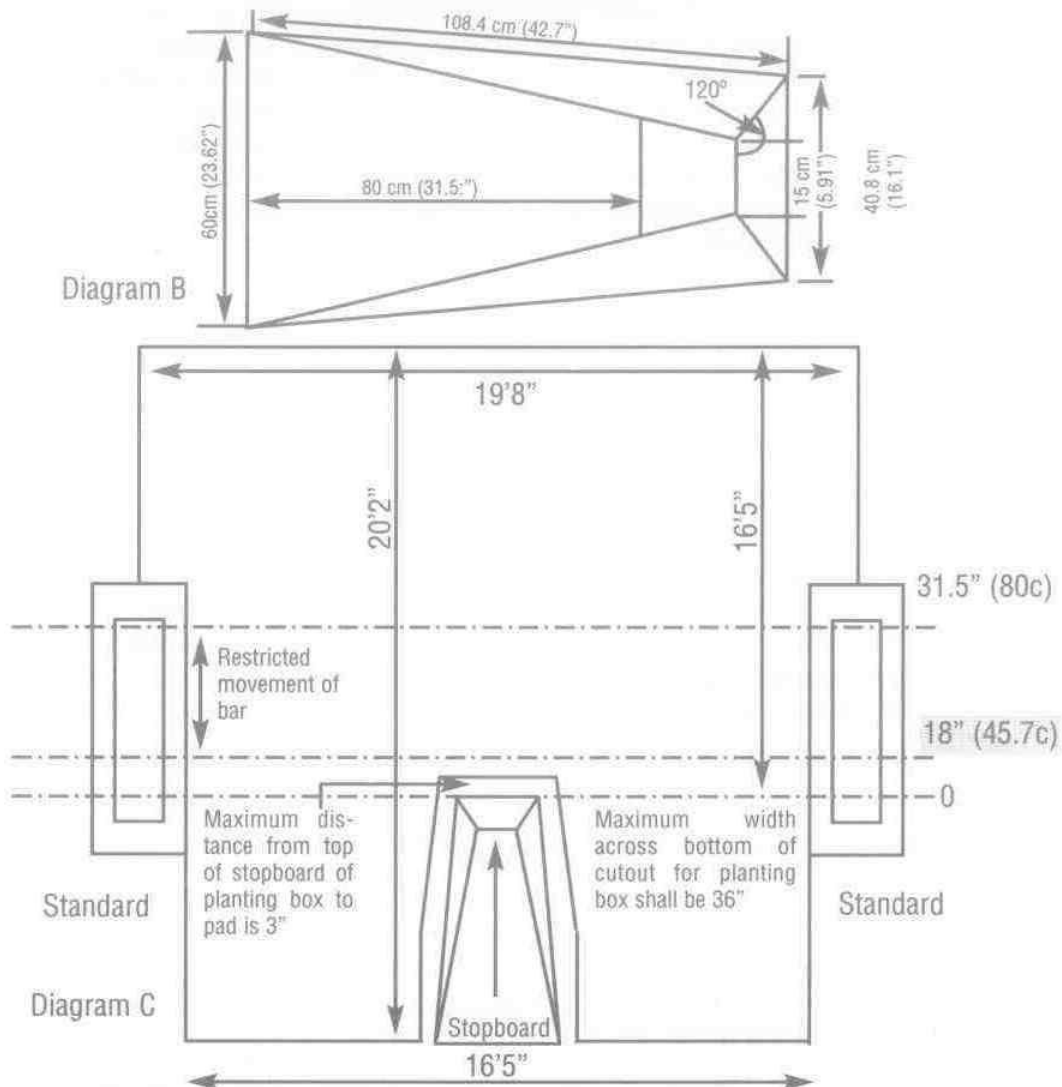

LANDING SYSTEM: The standards or uprights shall be set to position the crossbar from a point 18 inches (45.7c) beyond the vertical plane of the top of the stopboard, up to a maximum distance of 31.5 inches (80c) in the direction of the landing surface.

The intent of this early notification is to alert all schools to the changes so that any necessary adjustments can be made.



2018 CIF
Pole Vault Sign-In/Verification

NFHS Track and Field Rules Rule 7 Section 5 Pole Vault

- Art 2 The vaulting pole may be of any material and of any length and diameter. It may have a binding of not more than two layers of adhesive tape of uniform thickness. However, the bottom of the pole may be protected by several layers of tape, PVC, metal, sponge rubber or other suitable material to protect it when placed in the planting box.
- Art 3 The competitor=s weight shall be at or below the manufacturer=s pole rating. The manufacturers must include on each pole: the pole rating that shall be a minimum of : inch in a contrasting color located within or above the top handhold position; a 1-inch circular band indicating the maximum top handhold position with the position being determined by the manufacturer. Prior to competition, the coach must verify that all of the schools= pole vaulters meet these requirements.
- Art 4 A competitor shall not use a variable pole, a pole which is improperly marked or a pole rated below his/her weight during warm-up or competition.

Meet: _____ Location: _____ Date: _____

Position	Athlete's Name	School	Weight of Athlete	Coach's Signature	Poles Inspected by Official
1					
2					
3					
4					
5					
6					
7					
8					
9					
10					

Track and Field and Cross Country Rules Changes - 2018

By NFHS on July 27, 2017

4-3-1, 4-3-1b, 4-3-1c: Clarifies that for a track and field as well as cross country uniform to be considered legal, the singlet and bottom or one-piece uniform shall be school-issued or school-approved. This change for school approval addresses the need for athletes to purchase a part of their uniform, but such individual apparel shall be approved by the school coach to be certain it meets all rule requirements.

Rationale: Clarifies that the school may issue or approve an individually purchased item as part of the official school uniform.

6-2-14 PENALTY (NEW), 6-2-10, 6-2-13: Several prohibitions regarding competitors' actions were included but had no associated penalty should the rule not be followed which created confusion for enforcement. The appropriate penalty of disqualification from the event has been added.

Rationale: This rule was absent the necessary penalty.

6-5-11: The requirements for the length of the pole vault crossbar has become more flexible as it can now be within a range in length like the high jump.

Rationale: Creates consistency in establishing a range for the length of the crossbar in pole vault. Provides flexibility in the length of the crossbar, like the high jump crossbar.

8-6-1 (NEW), 4-3: Duplicate language regarding the uniform has been removed from Rule 8, Cross Country, and all rules regarding the uniform for individuals, relay team members and cross country teams are now all contained in one rule, Rule 4.

Rationale: Eliminates duplicate language. These two rules are identical except for the rule on the soles of the shoes allowing for one-inch spikes in cross country.

Major Editorials

4-6-1 NOTE 2, 3-1 NOTE: Establishes consistent NFHS language within the rules prohibiting the use of tobacco products and similar items and alcohol by participants, school personnel or officials.

5-3-1: Provides greater flexibility by expanding the professional positions which are qualified to survey and measure a track.

6-7-2: Corrects clerical error in maximum diameter for the boys indoor shot put.

6-8-9: Removes duplicate language which is covered in Rule 6-2-10 regarding broken javelin.

6-9-8: Removes duplicate language which is covered in Rule 6-2-3 regarding excused competitors.

2017-18 Track and Field Editorial Changes

3-10-2, 4-3-1b(4), 5-2, 6-1-8, 6-2-6 PENALTY, 6-2-15, 6-2-16, 6-2-17, 6-6-5, 8-7

2017-18 Track and Field Points of Emphasis

1. Uniforms-Waistbands, Trim, Accents and Compliance
2. Providing Fluids to Competitors at Cross Country Competitions
3. Entry Limits for Individual Contestant
4. Officials Safety and Recommendations in the Long Throws



PROUDLY SUPPORTING
SO CAL
HIGH SCHOOL ATHLETES



SoCalFordDealers.com

