

CIF SOUTHERN SECTION | TRACK & FIELD



SEASON PREVIEW



2025 - 2026



F-150

Mustang Mach-E

Bronco

Explorer

Our vehicles. Your athletes.

The Southern California Ford Dealers proudly support SoCal High School Athletics.

SoCalFordDealers.com | CIFSS.org



Table of Contents – Track and Field 2025-2026

2025-2026 TRACK AND FIELD ADVISORY COMMITTEE	4
TRACK AND FIELD CALENDAR DATES	5
TRACK AND FIELD APPROVED SANCTIONED EVENTS	6
CIFSSHOME.org REQUIREMENTS	7
RULES - BLUE BOOK BYLAWS - SPECIAL POINTS OF INTEREST	8
BLUE BOOK BYLAWS -	8
• STANDARDS OF ELIGIBILITY	8
• BASIC ELIBILITY REQUIREMENTS FOR PARTICIPATION	8
• ACCOUNTABILITY	8
• PLAYER CONDUCT	8
• SUMMERTIME RULES/SUMMER DEAD PERIOD/SUNDAY RESTRICTION	8
• PRACTICE ALLOWANCE	8
• SUPERVISION OF ATHLETES.....	8
• OUTSIDE COMPETITION.....	8
• BYLAW 600 PENALTY	8
OTHER POINTS OF INTEREST	9
NFHS RULE CHANGES – Track (Spring 2026/Cross Country Fall 2026).....	9
PLAYOFF INFORMATION	11
PLAYOFF DATES	11
2025-2026 CIF-SS BOYS & GIRLS TRACK AND FIELD PLAYOFF DIVISIONS/HYTEK CODES..	12
CIF SOUTHERN SECTION 4x800 METER RELAY – NEW FORMAT IN 2026	12
CIF SOUTHERN SECTION CHAMPIONSHIP QUALIFYING INFO	13
“WILD CARD” INCLUSION INTO CIF-SS PRELIMS	13
FREELANCE ENTRIES INTO CIF-SS PRELIMS STANDARDS	14
DISCUS CAGE SPECIFICATIONS.....	15
CIF RULES FOR THE POLE VAULT.....	16
CIF POLE VAULT SIGN-IN/VERIFICATION FORM.....	19
HEALTH & SAFETY	20

2025-2026 TRACK AND FIELD ADVISORY COMMITTEE

Over the past years, the CIF-SS office has worked with the concept of establishing advisory committees in most of the sports for boys and girls. The role of the advisory committee, comprised of coaches in the respective sport and an administrator from the CIF-SS office, may include the following:

1. Meetings
2. Recommendations for playoff sites
3. Recommendations for procedural changes
4. Recommendations for rule changes
5. Evaluation of sport season
6. Assistance to coaches and/or official's organizations
7. Liaison between coaches and the CIF-SS office

For your reference, members of the 2025-2026 Track and Field Committee and the Management Committee are:

ADVISORY / MANAGEMENT COMMITTEE	
JT Ayers, Trabuco Hills HS	Bryan Leighliter, Gahr HS
Rich Benoy	Joe McNab, Notre Dame/SO HS
Keith Chann, Temescal Canyon HS	Guadalupe Nieves, Ontario HS
Rob Dearborn, Moorpark HS	Mary Perez, Camarillo, HS
Mark Gardner, Corona HS	CB Richards, South Pasadena HS
Stirley Jones, Yorba Linda HS	Richard Rico, Ontario HS
Dennis Kelly, Trabuco Hills HS	Mo Russell, Mira Costa HS
Jonas Koolsbergen, Harvard Westlake HS	Jaime Sandoval, Rosary HS
Van Latham, Carpinteria HS	Keith Thompson, Walnut HS

TRACK AND FIELD CALENDAR DATES

The following is a capsule of the CIF Southern Section calendar for the Boys and Girls Track and Field season.

FIRST CONTEST:

The initial date on which a school may schedule and conduct an interscholastic contest is **SATURDAY, FEBRUARY 21, 2026.**

SCRIMMAGE:

A scrimmage is defined as:

An activity involving teams or individual student-athletes from two or more different schools in a CIF approved sport; AND

Where no official score is kept; AND

Where regulation time is not kept; AND

Where substitute rules are set aside; AND

Where coaches may stop play for instructional purposes; AND

Where no score/results are released to the media.

Number of Scrimmages: A maximum number of two (2) scrimmages are permissible prior to the first interscholastic contest (league or non-league)

LAST LEAGUE CONTEST:

All league competition for entries must end on or before **FRIDAY, MAY 1, 2026.**

MAXIMUM CONTEST:

An individual of a track and field team will be permitted to enter and participate in no more than a total of 14 dual, triangular or invitational (sanctioned) meets during the season, not including all-league or CIF Southern Section Championships.

COMPETITION IN ONE DAY:

No student will be permitted to enter two different meets on the same day. A student may compete in different classifications during a calendar week but not in the same meet. League prelims and finals are considered to be one meet, as are the CIF Southern Section prelims and finals.

PLAYOFF DATES:

Divisional Prelims: Saturday, May 9, 2026 – 4 sites

Divisional Finals: Saturday, May 16, 2026 – Moorpark High School

Masters Meet: Saturday, May 23, 2026 – Moorpark High School

State Track Meet: Friday and Saturday, May 29 and 30, 2026 - Clovis

TRACK AND FIELD APPROVED SANCTIONED EVENTS

Please refer to the CIF Southern Section website (www.cifss.org) for the latest Sanctioned Events, as events are updated daily.

Sanctioned Events download directions:

Click on *GOVERNANCE TAB* > click on *SANCTIONED EVENTS* > select *Track and Field* > click Search

This page will display the most up to date information on Track and Field Approved Sanctioned Events.



CUSTOM JACKETS

SPECIALIZING IN CIF PATCHES, LETTERMAN JACKETS, VARSITY LETTERS AND CUSTOM PATCHES



- Official CIF-SS Patch Manufacturer for: Champions, Finalists, All-CIF, Athlete of the Year and Unified Sports
- Official CIF-SS Letterman Jacket Partner
- League patches, custom patches, varsity letters, & emblems available
- Banquet dates guaranteed
- 2 – 3 Week turnaround time on all orders



Place your order online today at www.jlcustomjackets.com
Contact us at: 951-867-3200 or customerservice@jlcustomjackets.com
Locations in: Moreno Valley and Anaheim



CIFSSHOME.org REQUIREMENTS

VARSITY TEAM INFORMATION (ROSTER)

Attention Athletic Directors/Coaches: It is very important that you enter your entire Boys/Girls Track and Field roster into CIFSSHOME.org (no later than **WEDNESDAY, APRIL 29, 2026.**

Log in @ www.cifsshome.org (If you do not have a log in & password as a coach, check with your Athletic Director).

- Click on the “**Teams**” tab, click on “**Teams Manager**”, click on “Track , Boys or Track, Girls”, select “Vr”

You can UPLOAD your roster using the instructions below (1) or you can enter each player one by one (2).

Required roster information for Boys/Girls Track and Field is: First Name, Last Name, Birth date, Year, & Eligibility

(1) To ADD roster players one by one:

- Click on “+Add Players One By One” and complete fields required for Boys/Girls Track and Field.

(2) To Import a Roster using an Excel sample file:

- Download the [sample file](#) **and** delete the “contents only”.

- Copy and paste or type your roster information into the file as the contents and save the file to your computer.

- Only an excel file (**xls**) can be uploaded that is the exact same format as the sample file.

- Columns for information not required for your sport may be left blank, but the HEADER INFORMATION MUST REMAIN EXACTLY AS THE SAMPLE.

- Required Columns for Boys/Girls Track and Field are: First Name, Last Name, Birth date, Year, & Eligibility

- Click on “Choose File” to find your file, then click on “Import”

- To confirm the roster has been uploaded, your players’ names will be uploaded in the “**Official Roster**” section

- Click on the “Pencil” edit button next to the player’s name to view each player’s information.

IMPORTANT: Complete process for both Boys and Girls Track Rosters

RULES - BLUE BOOK BYLAWS - SPECIAL POINTS OF INTEREST

Following are key points/highlights coaches should review with their assistants and participants in reference to the NFHS Rule Book and CIF-SS rules and regulations as defined in the 2024-2025 Blue Book.

BLUE BOOK BYLAWS -

- STANDARDS OF ELIGIBILITY – BYLAW 201
<https://cifss.org/resources/blue-book/?gotopage=53>
- BASIC ELIBILITY REQUIREMENTS FOR PARTICIPATION – BYLAW 220
<https://cifss.org/resources/blue-book/?gotopage=87>
- ACCOUNTABILITY – BYLAW 125/503

125.1 - COACH EJECTION
<https://cifss.org/resources/blue-book/?gotopage=47>

503 – COACH EJECTION
<https://cifss.org/resources/blue-book/?gotopage=101>

125.2 - FAILURE TO COMPLETE A CONTEST
<https://cifss.org/resources/blue-book/?gotopage=47>
- PLAYER CONDUCT – BYLAW 503
<https://cifss.org/resources/blue-book/?gotopage=101>
- SUMMERTIME RULES/SUMMER DEAD PERIOD/SUNDAY RESTRICTION
– BYLAW 1223
<https://cifss.org/resources/blue-book/?gotopage=140>
- PRACTICE ALLOWANCE – BYLAW 506
<https://cifss.org/resources/blue-book/?gotopage=107>
- SUPERVISION OF ATHLETES – BYLAW 503
<https://cifss.org/resources/blue-book/?gotopage=97>
- OUTSIDE COMPETITION – BYLAW 600
<https://cifss.org/resources/blue-book/?gotopage=114>
- BYLAW 600 PENALTY – BYLAW 601
<https://cifss.org/resources/blue-book/?gotopage=116>

OTHER POINTS OF INTEREST -

1. **MAXIMUM CONTEST** - An individual of a track team will be permitted to enter and participate in no more than a total of 14 dual, triangular or invitational (sanctioned) meets during the season, not including all-league or CIF Southern Section Championships.
2. **MAXIMUM NUMBER OF MEETS/DAY** -- No student will be permitted to enter two different meets on the same day. A student may compete in different classifications during a calendar week but not in the same meet. League prelims and finals are considered to be one meet, as are the CIF Southern Section Prelims and Finals.

MAXIMUM NUMBER OF EVENTS: A STUDENT MAY ENTER A TOTAL OF NOT MORE THAN FOUR EVENTS IN ANY ONE MEET. These may be four running events or four field events or any combination of track and field events totaling not more than four.

3. **OUTSIDE COMPETITION** - (Unattached) competition is permissible for a student in other than school contests during the season of sport. Please refer to Blue Book Rule 600 regarding unattached competition which will highlight specific regulations in reference to athletes who compete unattached.
4. **PROPER UNIFORM** - All Athletes competing in track and field must be in proper team uniform and wear running shoes.
5. **LEVEL OF COMPETITION** -- No student shall participate in more than one level of competition in the same sport in the same day.
6. **RULES** – Track and Field competition in the CIF Southern Section is conducted under National Federation Rules, which are contained in the most current edition of the National Federation Track and Field Rule Books.
7. No interscholastic contests or practices of any kind are to be held on Sunday.

NFHS RULE CHANGES – Track (Spring 2026/Cross Country Fall 2026)

Track and Field Rules Changes – 2026

BY NFHS ON November 7, 2025 | additional info can be found at <https://nfhs.org/sports/track-field/rules>

TRACK & FIELD/CROSS COUNTRY, RULES, CROSS COUNTRY

3-2-3k: The games committee has the authority to determine takeoff board placement in the horizontal jumps aligning with existing rule in setting starting heights for vertical jumps. Athletes may still change which approved takeoff board to use during competition.

3-8-6: The rule change recognizes the increasing cost and limited availability of .32 caliber blanks used in starting devices. By expanding the range of acceptable calibers, meet management is provided greater flexibility in selecting starting equipment, while maintaining the safety, reliability, and functionality necessary for proper race administration. Electronic or gunless devices are also still permissible.

4-6-5: The change affirms that the safety of student-athletes is a top priority and supports the use of appropriate health care professionals to evaluate a downed competitor on the course when designated by the games committee. This evaluation may occur without resulting in disqualification, provided the competitor is not assisted in progressing

along the course. This interpretation maintains the integrity of the competition while ensuring that timely medical evaluation can occur when necessary. It reinforces the balance between competitive fairness and the health and well-being of participants.

4-6-6c: The rule clarifies that athletes are not permitted to wear any audio or video recording or transmitting devices during a race, trial, or while in restricted areas. This restriction minimizes potential distractions and interference with performance. This language is consistent with policies found in other NFHS rules books and reinforces a uniform standard across interscholastic sports.

6-2-2 NOTES (3) NEW: The addition of the note clarifies changes made in previous years that the time limit for a consecutive attempt applies within a height and at a height change.

6-3-2b4(a): The committee supports the continued inclusion of metric measurements alongside imperial units in the rules book to promote clarity and consistency in meet management. This approach acknowledges the increased use of metric measurements in field events. Standard metric progressions are typically 5cm increments with 15cm aligning closely to the traditional 6 inches. Including both units supports coaches, athletes and officials in conducting fair and accurate competition and ensures the rules book remains a practical resource for all users.

6-8-6: In large competitions, the current rule allowing warm-up only after passing three consecutive heights can result in extended periods of inactivity, sometimes exceeding an hour, for athletes who enter later in the event. This can pose both a competitive disadvantage and a potential safety concern. The revised rule promotes fairness, consistency, and risk minimization. This change ensures that all athletes have an adequate opportunity to prepare, regardless of when they enter the competition.

6-9-21 and 6-9-28: The rule change clarifies that the padding requirement applies specifically to hard and unyielding surfaces that are elevated relative to the ground. This refinement helps differentiate between surfaces that present a greater risk of impact during a fall (such as raised concrete, asphalt, wood, or platform extensions) versus ground-level areas that may already be accounted for with landing system setup.

6-10-5: The addition of the implement construction specifications for the javelin ensures that all necessary information is readily available, specific to the high school level, and aligned with the intent of education-based athletics. This addition reinforces consistent equipment standards and enhances clarity and accessibility for high school coaches, athletes and meet officials.

9-1-1: The addition of the 200-meter dash to indoor meets provides states with greater flexibility to structure events based on facility size and meet goals.

9-6-1: The rule change establishes a uniform 20-meter exchange zone for indoor relays and creates a single standard for ease in officiating.

PLAYOFF INFORMATION

PLAYOFF DATES:

CIF-SS TRACK AND FIELD CHAMPIONSHIP DATES FOR 2026 – Boys and Girls Varsity

This may be used for preliminary planning, as more comprehensive information will follow in a later bulletin.

All Prelims are on Saturday, May 9, 2026

DIVISION 1 PRELIMS

Trabuco Hills HS

Meet Management:

JT Ayers

ayersj@svusd.org

(949)768-1934

Dennis Kelly

dennis.kelly@svusd.org

(562)355-9474

3/16" pyramid spikes only @ Trabuco Hills

DIVISION 2 PRELIMS

Ontario HS

Meet Manager:

Guadalupe Nieves

guadalupe.nieves@cjuhsd.net

(909) 988-7411

Richard Rico

richard.rico@cjuhsd.net

DIVISION 3 PRELIMS

Yorba Linda HS

Meet Management:

Stirley Jones

stjones@pylusd.org

(949) 245-5205

Keith Chann

keith.chann@leusd.k12.ca.us

(951) 663-3886

DIVISION 4 PRELIMS

Carpinteria HS

Meet Manager:

Van Latham

vlatham@cusd.net

(805) 684-4107

Div 4 Prelim information: <http://www.warriorcountry.com/track/CIF.htm>

DIVISIONAL FINALS

Moorpark High School

--

Saturday, May 16, 2026

Meet Manager: Rob Dearborn

(805) 378-6305, Ext. 2363

rdearborn@mrpk.org

Canopies and Umbrellas are only allowed in the top row of the stadium

MASTERS MEET - STATE QUALIFYING

Moorpark High School

--

Saturday, May 23, 2026

Meet Manager: Rob Dearborn

(805) 378-6305, Ext. 2363

rdearborn@mrpk.org

Canopies and Umbrellas are only allowed in the top row of the stadium

STATE TRACK MEET

Buchanan HS - Clovis

--

Friday and Saturday, May 29 and 30, 2026

2025-2026 CIF-SS BOYS & GIRLS TRACK AND FIELD PLAYOFF DIVISIONS/HYTEK CODES

As a result of the CIF Southern Section Council decision (*March 23, 2000), for the 2025-2026 Track and Field season, league qualifiers for the CIF Southern Section Prelims will advance to their division based on the previous year's (2024-2025) CBED enrollment figures for their individual schools.

In order to address some concerns expressed by the Track and Field Advisory Committee and in an effort to avoid introducing, at this time, more drastic changes (i.e., additional minimum standards, capping entries, etc.) you will note that there have been some slight adjustments in the divisional makeup.

Leagues using Hy-Tek for their prelim/final meets must only use the school abbreviations listed on the divisional breakdown sheets. No other abbreviations can be used.

Track & Field division placements and Hytek codes can be found at <https://cifss.org/sports/track-field/>

CIF SOUTHERN SECTION 4x800 METER RELAY – NEW FORMAT IN 2026

4x800M Relay Postseason Format Into CIF-SS Prelims (*NEW*)

For 2026, the 4x800 Meter Relay will be contested at the Divisional Prelims meets and will be a scoring event at the Divisional Finals meet.

The qualification and advancement format will be as follows:

- Teams must run the 4x800 relay at CIF-sanctioned meets (invitationals and/or league prelims/finals meets only) to achieve qualification times, which must be submitted via email.
- The verified top twenty-four (24) teams per gender, per division by the deadline date will qualify for their respective Divisional Prelims meet. A maximum of one(1) entry per school per gender is allowed (no "B" teams).
- Two (2) heats of the 4x800 per gender will be contested at each Divisional Prelims meet.
- The two (2) heat winners plus the remaining seven (7) fastest times for a total of nine (9) teams per division at each Divisional Prelims will advance to the Divisional Finals.
- At the Divisional Finals meet, there will be two (2) 18-team races per gender using combined divisions (similar to the combined-divisions format now used for the 3200-meter run).
- The four (4) divisional champions plus the remaining eleven (11) fastest teams by time will qualify for the Masters Meet, which serves as the state championship qualifier. The Masters Meet will feature a single-heat, 15-team final.
- Note: At all CIF-SS postseason meets (Prelims, Finals and Masters), the 4x800m races will be scheduled to occur in between the 200m and the 3200m events.

ENTRY PROCESS TO COMPETE IN THE 4x800 RELAY AT THE MASTERS MEET:

Participate > Submit Time > Qualify > Compete

1. Participate in any CIF-SS sanctioned invitational/meet in the 4x800 event during the 2025-26 CIF Southern Section track and field season of sport.

2. Submit your team's recorded time from that meet found on the CIF-SS 4x800 Leader List on the PrepCalTrack website (<https://prepcaltrack.com/>) for inclusion by sending an email to CIFSS4x800@gmail.com .
Times must be submitted via email no later than **Friday, May 1, 2026**.
3. Coaches for the top 24 verified teams in each gender in each division will be notified via email on Monday, May 4th that they've qualified into the Divisional Prelims; relay pool names (maximum of eight names) will be requested at that time. No additional teams will be added if teams in the top 24 scratch or decide not to run after declaring their times for the meet by the deadline.

CIF SOUTHERN SECTION CHAMPIONSHIP QUALIFYING INFO

Each league has been allotted 1 automatic entry per event for the Southern Section Divisional Track and Field Divisional Preliminaries.

1. The league champion in each event will automatically qualify. The athlete **MUST** have competed in the league finals and attained a time/mark in league finals. A disqualification, DNF, dropped baton, no height, etc. does **NOT** count as a qualifying mark and these athletes/relay teams will **NOT** be allowed to be advanced to Prelims.
2. Second and third place finishers will qualify **IF** they meet the minimum standard for their event. That standard can only be achieved in the varsity league finals competition. In leagues with only four schools, there are only two total entries. Qualifying marks are available on the CIF-SS Website: <https://cifss.org/sports/track-field/>
3. Fourth place finishers and higher must meet the At-Large standard, available on the CIF-SS website: <https://cifss.org/sports/track-field/>

League Meet Managers are responsible for uploading results of their league finals to MileSplit by Friday, May 1, 2026 at 11:59pm.

"WILD CARD" INCLUSION INTO CIF-SS PRELIMS

To be considered for wild card inclusion into CIFSS Prelims, any athlete or relay competing at their league finals meet will advance into the meet if:

- Athlete whose mark at their league finals meet is in the top twelve (including ties) for their division as published on the CIF-SS Prelims performance list on May 2, 2026, but failed to:
 - achieve a top three result at league finals
 - and/or failed to receive a mark that meets the "at-large" standard for their CIF-SS division at league finals

Coaches with individual athletes or relay teams whose performance at the league finals meet puts them into this situation should confirm their top twelve status on the final CIF-SS Prelim performance list on MileSplit on May 2, 2026 and contact the Prelim Meet Manager for their division with official results from their league finals meet so that their athlete can be included in the CIF-SS Prelim field as a "Wild Card" entry.

The deadline for "Wild Card" entry submission to the Prelim Meet Manager is **10:00am on Monday, May 4, 2026** following the submission of entries by league meet managers. **Anyone who misses the deadline will not be entered after that point.**

FREELANCE ENTRIES INTO CIF-SS PRELIMS STANDARDS

Coaches should consider the average of the last three years 9th place qualifier from the Divisional Prelims when making your freelance entry. An email from a school requesting entry for one or more individuals into the appropriate enrollment division should be sent to the CIFSS office – Jerryd@cifss.org. The email MUST come from the head coach and/or school athletic director include the following data:

- | | | |
|------------------------------------|-----------------------|------------------------------|
| 1. Event (specify boy/girl) | 3. Grade level | 5. Mark for the event |
| 2. Full name of the athlete | 4. School | 6. Date/Type of meet |

No freelance petitions will be accepted after noon on Wednesday, April 29, 2026.

DIVISION 1 PRELIMS

Trabuco Hills HS

Meet Management:

JT Ayers

ayersj@svusd.org

Dennis Kelly

dennis.kelly@svusd.org

DIVISION 2 PRELIMS

ONTARIO HS

Meet Management:

Guadalupe Nieves

guadalupe.nieves@cjuhsd.net

Richard Rico

richard.rico@cjuhsd.net

DIVISION 3 PRELIMS

Yorba Linda HS

Meet Management:

Stirley Jones

stjones@pylusd.org

Keith Chann

keith.chann@leusd.k12.ca.us

DIVISION 4 PRELIMS

Carpinteria HS

Meet Management:

Van Latham

vlatham@cusd.net

DISCUS CAGE SPECIFICATIONS

The use of a protective cage is required for the discus event. There will be a rear to the cage as well as sides that extend forward at least up to the front of the ring and preferably several feet beyond the front of the ring.

SUGGESTED DISCUS CAGE SPECIFICATIONS

Portable or permanent installation. It is recommended that the cage be constructed of heavy nylon netting or other material that will absorb the energy of the discus to prevent bounce back.

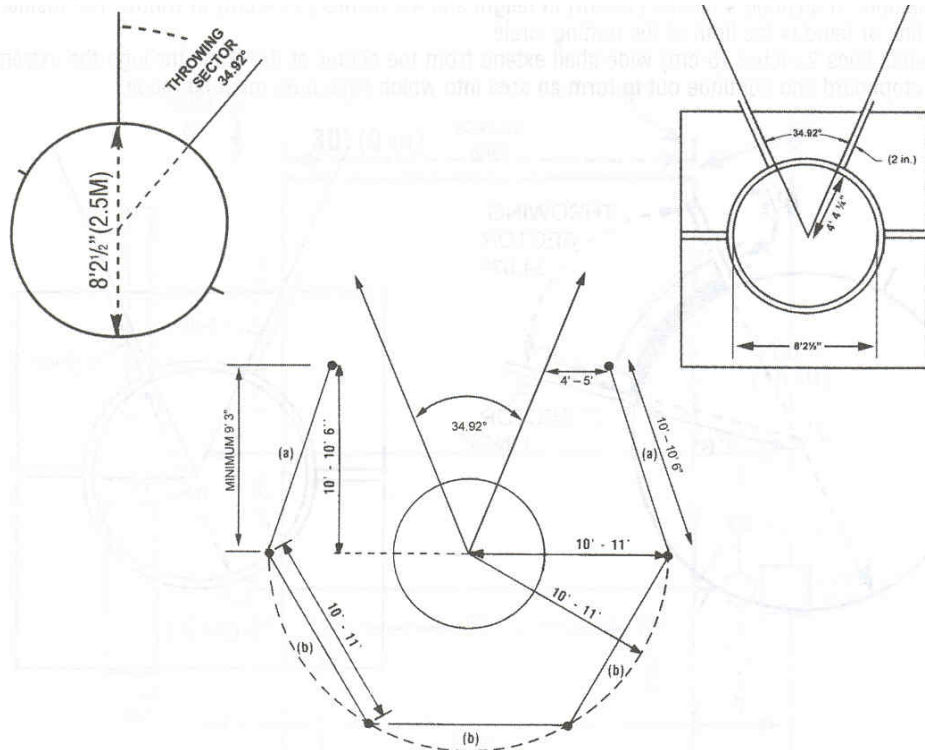

Suggested Specifications:

Height: 10' to 12'

Front Opening: 20'-24'

Distance from Corner Post to Sector Line: 4' to 5'

Distance from Center of Circle to Fencing: 10' to 11'

Fencing: Energy Absorbing Material

(a) 10' to 10'6"

(b) 10' to 11'

- Note:**
- 1) The above diagram of a discus throwing cage is designed to provide limited protection for competitors, officials and spectators in the immediate throwing area due to the nature of the event. It does not assure the safety of the aforementioned personnel.
 - 2) It is recommended that all throwing areas be roped and flagged to ensure the safety of spectators and athletes.

CIF RULES FOR THE POLE VAULT

The State CIF issues the following rules directive for immediate implementation in the pole vault event. National Federation Track & Field Rules 7-5-3 and 7-5-4 in the pole vault require important and necessary modifications in the conduct of the event. State High School Associations may exercise their authority to require a stricter enforcement of these rule changes. CIF coaches and officials must comply with and enforce all National Federation and State CIF rules. Failure to do so may jeopardize the safety of the event.

1. **Verification of Weight**

All coaches of high school track and field teams are required to present written verification to the starter-referee listing the current weight of each student pole vaulter prior to each high school meet. Such verification is to be recorded on an official **pole vault event card** appropriately designed with a space for the listing of the vaulter's weight plus the signature/initials of the coach. The pole vault event card is an **official record**.

a) **Dual Meets** - Each school shall enter competitors on their own event cards i.e. entrants from two or more schools should not be on the same entry card. Each school will be responsible for retaining a permanent file of the event cards in the office of its athletic director.

b) **Invitationals, League Championships, Section Championships, State Championships** - All entrants may be listed on a single event form and coaches are required, at check-in time, to enter the current weight for each vaulter, and place their initials on that official event form. The meet director is responsible for retaining the event form as an official record on permanent file.

2. **Inspection of the Poles - Penalty for Violation**

A. When the athlete checks in at the event, the pole vault event judge and/or the starter-referee will inspect the poles of each student vaulter to compare the signed, official pole vault event card (which lists each vaulter's current weight) against the numerical pole rating of all poles to be used by that student-vaulter. The above inspection shall be completed in order to approve each vaulter for subsequent practice vaults and official vaulting attempts. **Athletes who violate National Federation rule 7-5-3 which requires a vaulter to use a pole rated at the vaulters body weight, or above, will be disqualified from the pole vault event.**

NOTE: The CIF is not suggesting the event judge check the pole weight rating for every jump taken, but that the judge spot check the pole during warm-ups and competition for adequate compliance.

It is further clarified that should an athlete be disqualified; it would be a disqualification from the pole vault event only and not from the meet itself.

B. The pole vault event judge and/or starter referee may periodically check the poles of each student vaulter during practice or official vaulting attempts to insure: 1) the proper placement of a top hand-hold band 2) the numerical pole rating in one-inch numerals 3) proper pole bindings

REMARKING OF OLDER POLES

When the etching of printing listing the manufacturer's pole rating is no longer clearly visible, the pole may be remarked for possible use provided the pole has been reflexed according to the original manufacturer's specifications. The poles' numerical rating must be clearly marked according to National Federation rule specifications.

1. Safe Hand-Hold Zone - CIF Penalty for Violation

The top of the safe hand-hold zone shall be clearly marked with a one-inch circular band around the pole in contrasting color (National Federation Rule 7-5-3). **By State CIF rule, a violation of the safe hand-hold zone by a student-vaulter shall be deemed a failed try. A further violation shall be cause for disqualification.**

When checking for compliance, the one-inch circular band marking the top of the safe hand-hold zone must be "clearly visible" after the vaulter places his/her top hand next to that band.

2. Variable Weight Poles i.e. Training or Technique Poles

By State CIF rule, the variable weight pole shall not be used in any CIF high school competition. We note that expert vaulting coaches indicate there is some value in a variable weight pole, but its use must be restricted for short run, drill work and only during practice or training sessions and always under skilled supervision.

3. Box Collar Padding Requirement

7-5-24: Padding meeting the ASTM Specification Standards has been required since the start of the 2014-15 track season. Rationale: For the purpose of minimizing risk of injury to a pole vaulter, require that planting box padding shall meet the applicable ASTM Specification Standard.

ALL NATIONAL FEDERATION AND CIF RULES APPLY WHENEVER THE POLE VAULT EVENT IS CONTESTED REGARDLESS OF WHETHER THE EVENT IS SCORED OR NOT.

The landing surface measured beyond the back of the standard base protection pad, shall be a minimum of **19'8"** wide, and the dimension of the landing surface in back of the vaulting box to the back of the landing pad shall be **16'5"** deep. The material in the pad shall be high enough and of a composition that will **decelerate the landing**. When the landing pad is made up of two or more sections, the landing surface shall include a common cover or pad extending over all sections. (7-5-7) (7-5-8).

If the edges of the front, or landing pad, immediately adjacent to the planting box are not tapered, the back of the cutout may be placed no farther than **3 inches** from the top of the back of the planting box. (7-5-8)

The upright standards that support the crossbar shall be not less than **13'8" (4.16m) or more than 14'8" (4.48m)** apart, and the standards must include pins or holes for them to support the crossbar. (7-5-10)

The non-metal crossbar shall be 14'10" (4.52m) in length, of uniform thickness, and shall have a weight of not more than 5 pounds. (7-5-11)

A planting box shall be located midway between the standards. This box shall be constructed of concrete, fiberglass, metal, or other hard surface material into which the vaulting pole is placed. The box shall be of dimensions indicated in the accompanying Diagrams A and B, and it shall be placed so the top edges are at ground level. The box in Diagram B shall be constructed so that the sides slope outward at the end nearest the landing pit. The end of the planting box shall be placed at an angle of 105 degrees with the base of the box. **The front edge of the box shall not extend above the grade of the runway surface.** NOTE: It is recommended the planting box be of a color contrasting to the color of the runway. (7-5-12)

A minimum of 2" dense foam padding (box collar) shall be used to pad any hard and unyielding surface including **between the planting box and all pads.**

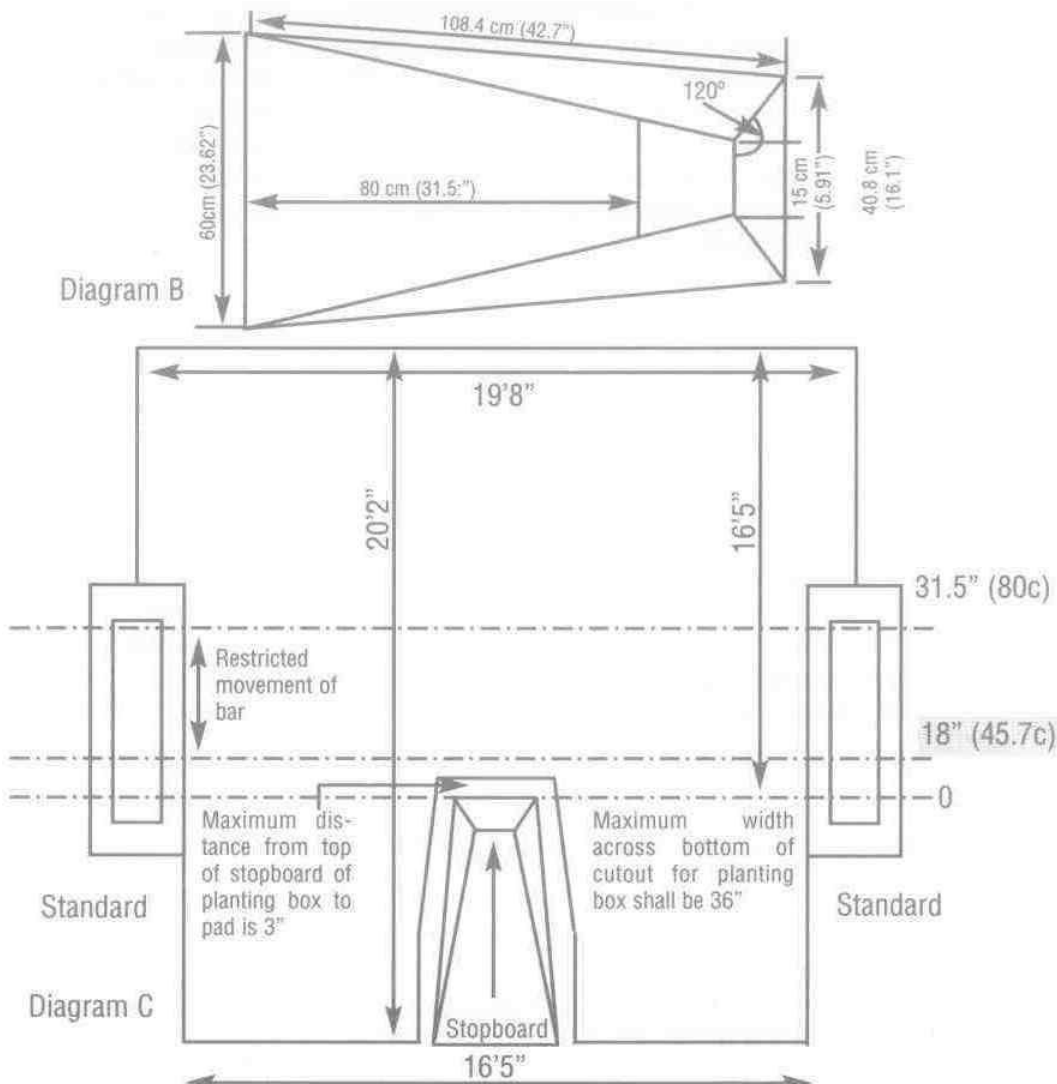

LANDING SYSTEM: The standards or uprights shall be set to position the crossbar from a point 18 inches (45.7c) beyond the vertical plane of the top of the stopboard, up to a maximum distance of 31.5 inches (80c) in the direction of the landing surface.

CIF POLE VAULT SIGN-IN/VERIFICATION FORM

NFHS Track and Field Rules Rule 7, Section 5 - Pole Vault

- Art 2 The vaulting pole may be of any material and of any length and diameter. It may have a binding of not more than two layers of adhesive tape of uniform thickness. However, the bottom of the pole may be protected by several layers of tape, PVC, metal, sponge rubber or other suitable material to protect it when placed in the planting box.
- Art 3 The competitor's weight shall be at or below the manufacturer's pole rating. The manufacturers must include on each pole: the pole rating that shall be a minimum of 1-inch in a contrasting color located within or above the top handhold position; a 1-inch circular band indicating the maximum top handhold position with the position being determined by the manufacturer. Prior to competition, the coach must verify that all of the schools' pole vaulters meet these requirements.
- Art 4 A competitor shall not use a variable pole, a pole which is improperly marked or a pole rated below his/her weight during warm-up or competition.

Meet: _____ Location: _____ Date: _____

Position	Athlete's Name	School	Weight of Athlete	Coach's Signature	Poles Inspected by Official
1					
2					
3					
4					
5					
6					
7					
8					
9					
10					

HEALTH & SAFETY

It is the expectation of the CIF Southern Section that your Athletic Coaches and Administration will take every measure to ensure the health and safety of your student athletes.

Resource information and additional information regarding heat safety, hydration and other health and safety related articles can be found on the CIF-SS website @ www.cifss.org. Click link to “Sports Medicine” tab on the blue toolbar.

Additional resources can be found at www.cifstate.org under the “Sports Medicine” tab on the white toolbar.



**THE
BEST
USE
THE
BEST**

GATORADE



When pain gets in the way of doing what you love ...

Trust the experts at Hoag & Hoag Orthopedic Institute
Sports Medicine to get you back on the field.

Hoag & Hoag Orthopedic Institute Sports Medicine are proud
to be the Official Orthopedic & Sports Medicine Partner of the
CIF Southern Section.

**Hoag
Orthopedic
Institute.**

SPORTS MEDICINE



We are proudly founded by our premier physicians in partnership with Hoag.

© 2024, Hoag is a registered trademark of Hoag Memorial Hospital Presbyterian. All Rights Reserved.